

RUGGED COVER

Premium Vinyl Tri-Fold Cover Installation Instructions



1

1. Place the cover on front of truck bed.



7

7. Cover is laying down flat.

8

8. Secure rear clamps for a tight fit.

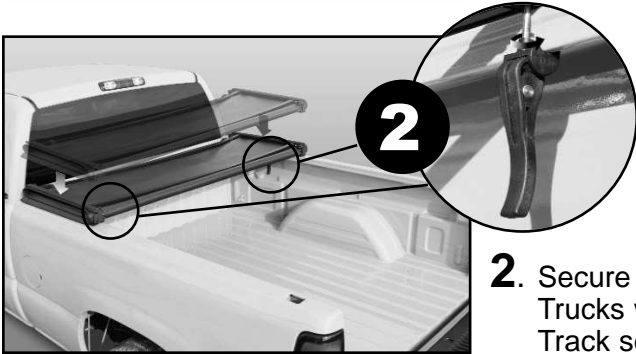

2

2. Secure front clamps. Trucks with Utility Track see Step 9.

9. Vehicles With Utility Track

- All Toyota Tacoma or Tundra Pickups.
- 2007 GMC/Chevy Pickups
- 2008 Ford Pickups
- 2008 Nissan Pickups
- 2008 Dodge Pickups

Use aluminum block to attach cover by sliding into place and locking clamping on to blocks. (See Back For Details)

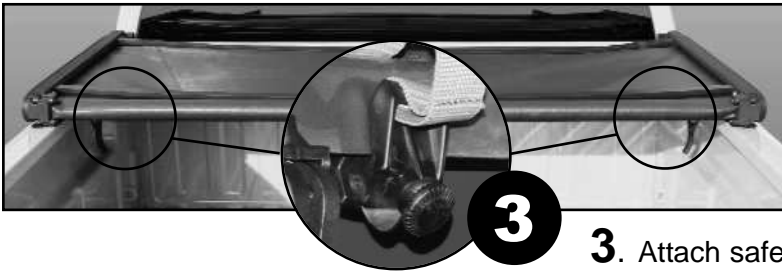

3

3. Attach safety tether strap on both sides.

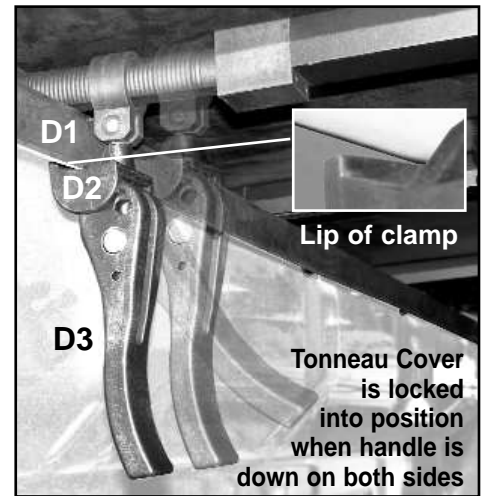

2&7. To clamp cover down, put lip of clamp under side bed rail and push handle down. (See D1, D2, D3)

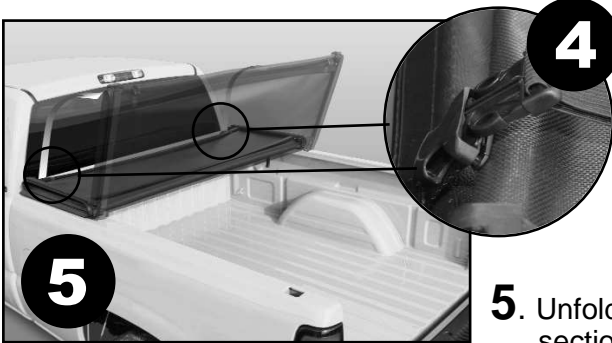

4

4. Undo both clips so cover can be unfolded.



5

5. Unfold first section.



Use orange clip to store clamp when cover is folded.



6

6. Unfold second section.

How To Adjust Clamps

- The clamps might need adjusted.
- To adjust, turn handle on clamp clockwise to tighten or counter clockwise to loosen.



200 Universal Dr. • Owosso, MI 48867 • 989-725-8354
Fax: 989-725-8409 • www.ruggedliner.com

Patent No. 7,823,957

FOR MORE INFORMATION CALL
1-800-433-3604

9 GM Pickups with Utility Track

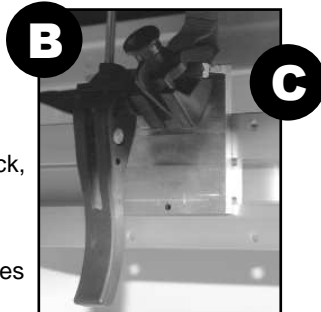

- A.** Slide aluminum blocks into track, position and tighten set-screw.
- B.** Secure front clamp on to aluminum block.
- C.** Attach safety strap on both sides to aluminum block.
- D.** Attach rear clamps

9 Nissan Pickups with Utility Track

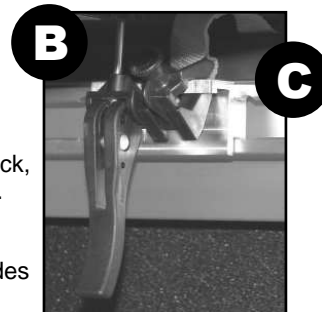

- A.** Slide aluminum blocks into track, position and tighten set-screw.
- B.** Secure front clamp on to aluminum block.
- C.** Attach safety strap on both sides to aluminum block.
- D.** Attach rear clamps

9 Dodge Pickups with Utility Track

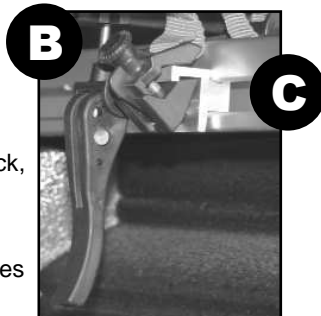
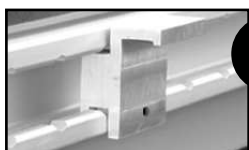

- A.** Slide aluminum blocks into track, position and tighten set-screw.
- B.** Secure front clamp on to aluminum block.
- C.** Attach safety strap on both sides to aluminum block.
- D.** Attach rear clamps

9 Toyota Pickups with Utility Track

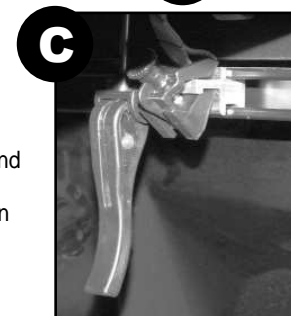
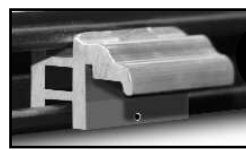

- A.** Loosen rear 2 bolt's on utility track and slide aluminum blocks into track.
- B.** Re-tighten rear 2 bolt's. Then position and tighten blocks with set-screw.
- C.** Secure front clamp & safety strap to aluminum block on both sides.
- D.** Attach rear clamps.

9 Ford Pickups with Utility Track

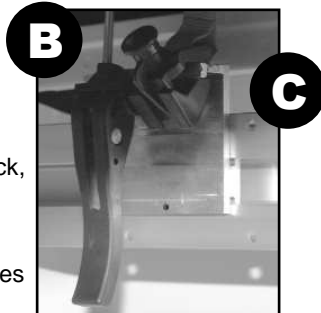

- A.** Slide aluminum blocks into track, position and tighten set-screw.
- B.** Secure front clamp on to aluminum block.
- C.** Attach safety strap on both sides to aluminum block.
- D.** Attach rear clamps

10 Useful Information.

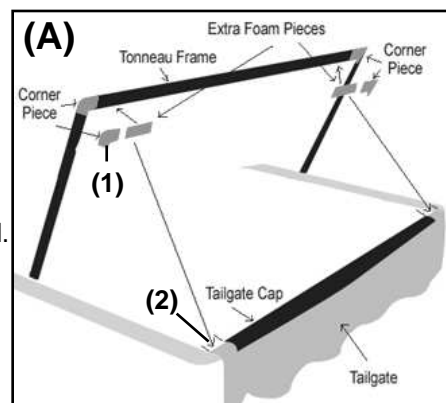

- A.** If there is a gap from the corner to the edge of the wing tailgate piece when the cover is fastened.
 - (1) You can put an extra foam corner piece on the back existing corner pieces.
 - (2) Take the roll of foam and measure from the edge of the tailgate piece to the edge of the corner piece on both sides, cut and stick to existing foam.
- B.** Or, Replace the Wing Style Tailgate Piece with a Flatter Style Tailgate Piece.